

**ITEM CODE: 800, 900, 800VR & 900VR SERIES
FIRE-EXIT HARDWARE WITH HALF OR FULL TOUCH BAR****Features:**

- Area of application: For single and double wooden and metal door.
- Standard material:
 - o 800 and 900 (Latch Touch Bar): End cover, body cover, lock body, push bar, centre cover, striking plate and latch bolt are stainless steel EN 1.4301 (type 304).
 - o 800 Silver and 900 Silver (Latch Touch Bar): End cover, body cover, lock body, push bar, centre cover, striking plate and latch bolt are steel (Q235-A)
 - o 800VR and 900VR (Bolt Touch Bar): End cover, body cover, lock body, push bar, centre cover, top and bottom covers are stainless steel EN 1.4301 (type 304).
 - o 800VR Silver and 900VR Silver (Bolt Touch Bar): End cover, body cover, lock body, push bar, centre cover, top and bottom covers are (Q235-A).
- One-locking point for 800/900 and two-point locking for 800VR/900VR.
- Anti-thrust latch function for 800/900.
- Single operation. Fully reversible.
- Supplied with:
 - o 800 and 900 series: 1 pc complete set latch touch bar, 1 pc keep (strike) for single leaf with full set of screws.
 - o 800VR and 900VR series: 1 pc complete set bolt touch bar, 1 pc top strike, 1 pc bottom strike, 1 set top latch, 1 set bottom latch, 2 sets clamps, 2 pc connect bar (for maximum door height 2133 mm).
- OAD (outside access device): as shown on catalogue.
- Strike plate (SPD003-A) for double leaf to be ordered separately.
- 900 and 900VR series touch bar length 845 mm.
- Optional: Request to Exit (REX) is available.
- UL listed and examined to UL 10C. UL unique identification number: GXHX.R25171.
- Examined in accordance with UL 305 ANSI A156.3-2008 requirements for Grade 1.
- BHMA Certified.
- Standard finish: satin stainless steel (SSS). Other finishes are available upon request.

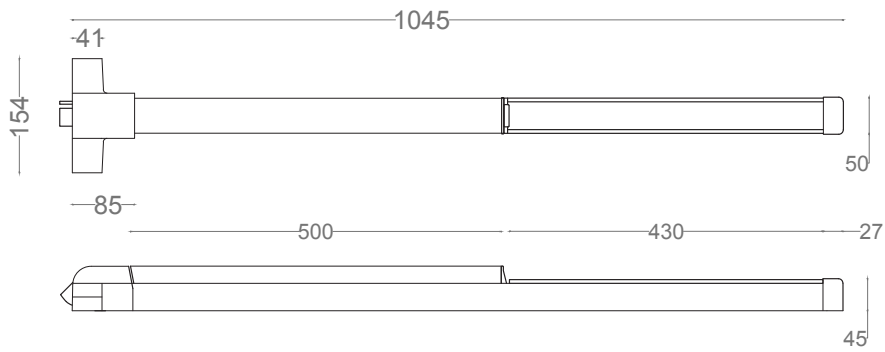

FIRE EXIT HARDWARE SERIES 800 & 900



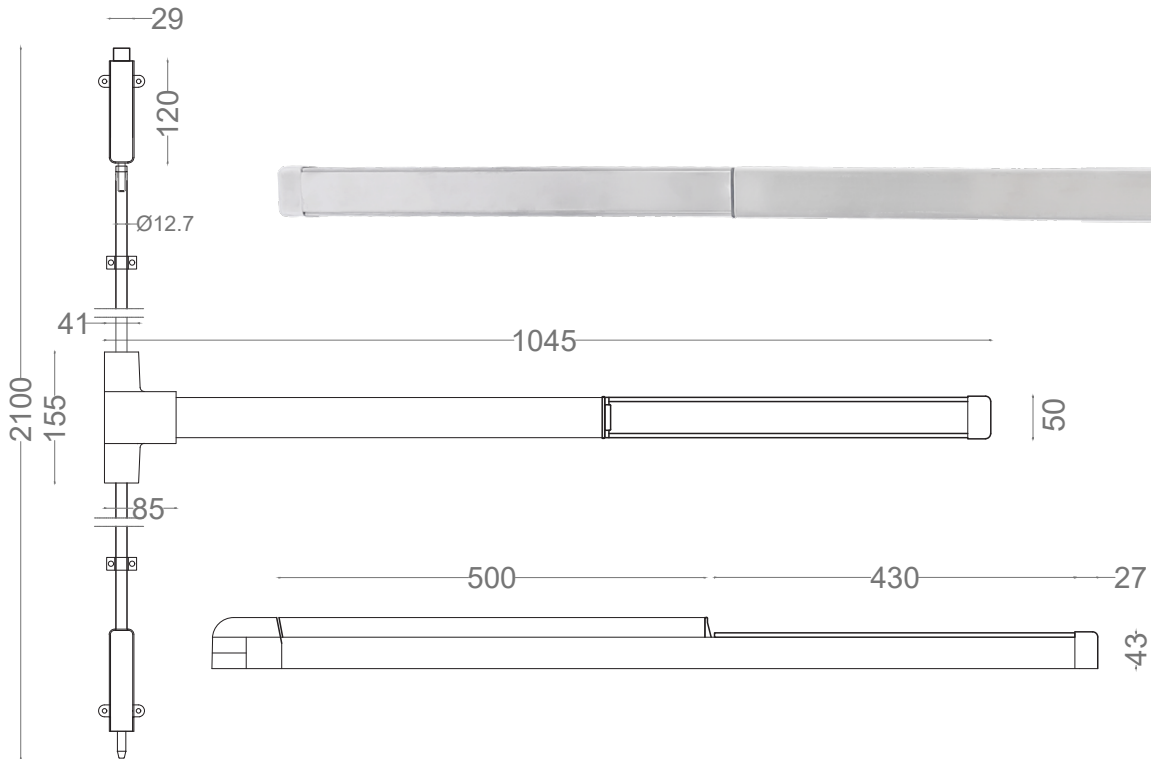

FIRE-EXIT HARDWARE 800

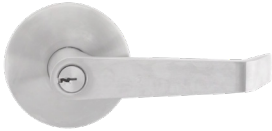
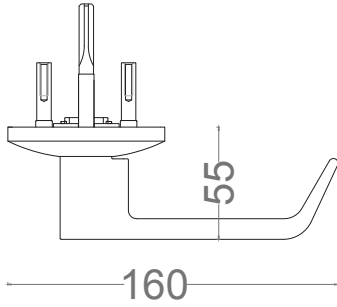

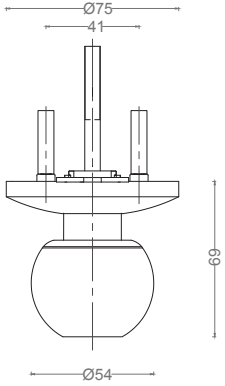

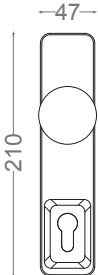
FIRE-EXIT HARDWARE 800VR

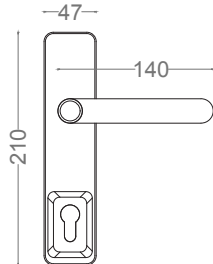

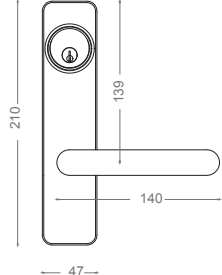
| DT004 | | DT006 | |
|-----------------------------------------------------------------------------------|-----------------------------------------------------------------------------------|------------------------------------------------------------------------------------|-------------------------------------------------------------------------------------|
|  |  |  |  |

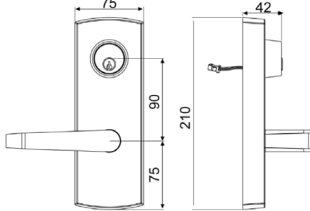
| DT008 | | DT010 | | DT009 | |
|------------------------------------------------------------------------------------|-------------------------------------------------------------------------------------|-------------------------------------------------------------------------------------|--------------------------------------------------------------------------------------|---------------------------------------------------------------------------------------|---------------------------------------------------------------------------------------|
|  |  |  |  |  |  |

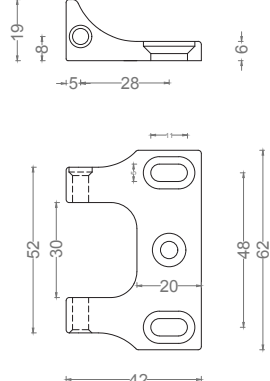
| DT109 (ELECTRIFIED) | | STRIKE PLATE FOR DOUBLE DOORS, SPD003-A | |
|-------------------------------------------------------------------------------------|-------------------------------------------------------------------------------------|--------------------------------------------------------------------------------------|---------------------------------------------------------------------------------------|
|  |  |  |  |

**ITEM CODE: 800D & 800VRD SERIES
UL LISTED FIRE-EXIT HARDWARE****Features:**



- Area of application: For single and double exit doors, active and inactive leaf.
- Material:
 - o 800D series (Panic Latch Touch Bar): Standard galvanized steel in US26D finish, optional in Stainless steel EN 1.4301(type 304) in US32D finish.
 - o 800VRD series (Panic Bolt Touch Bar): Standard galvanized steel in US26D finish, optional in Stainless steel EN 1.4301(type 304) in US32D finish.
- Features:
 - o One-locking point for 800D series and two-point locking for 800VRD series.
 - o Anti-thrust latch function for 800D series.
 - o Single operation, fully reversible.
- Supplied with:
 - o 800D series: 1 pc complete set panic latch touch bar, 1 pc keep (strike) for single leaf with full set of screws.
 - o 800VRD series: 1 pc complete set panic bolt touch bar, 1 pc top strike, 1 pc bottom strike, 1 set top latch, 1 set bottom bolt, 2 sets clamps, 2 pc connect bar (for max. door height 2415 mm) with full set of screws.
- OAD (outside access device): Several versions are available.
- Standard length of touch bar is 550 mm, optional 630 mm.
- UL listed and examined to UL 10C. UL unique identification number: GXHX.R25171
- Standard finish: Satin Chromium plated (US26D), optional Satin Stainless Steel (US32D). Other finishes are available upon request.

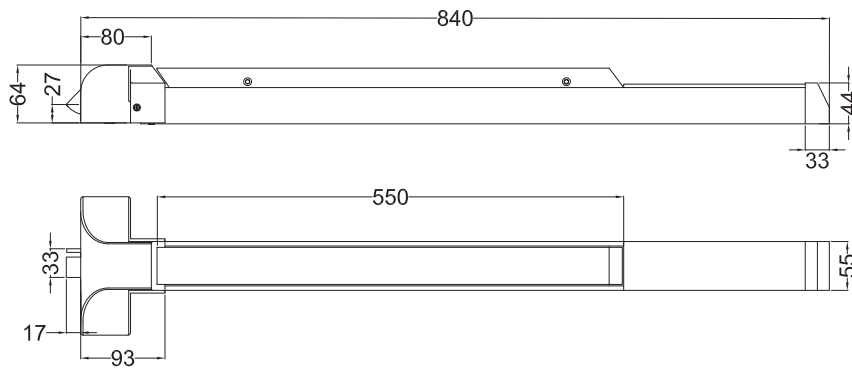

FIRE-EXIT HARDWARE 800D-550

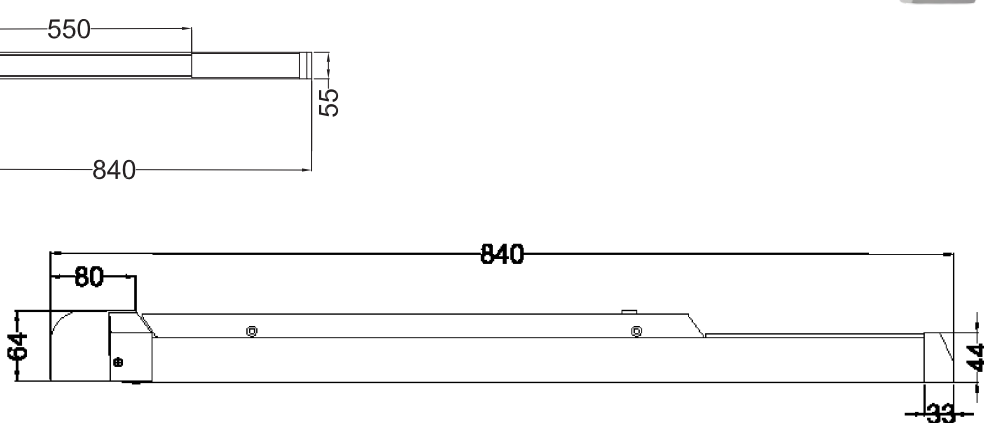
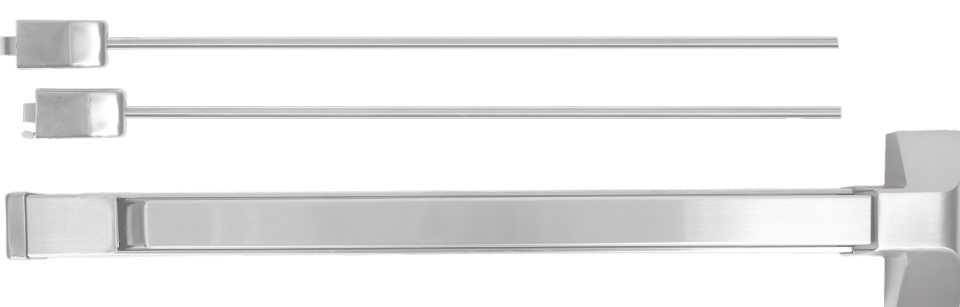
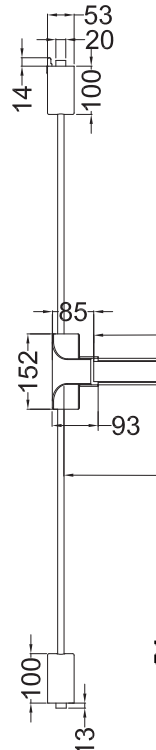
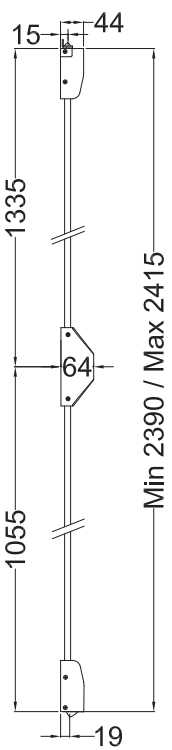

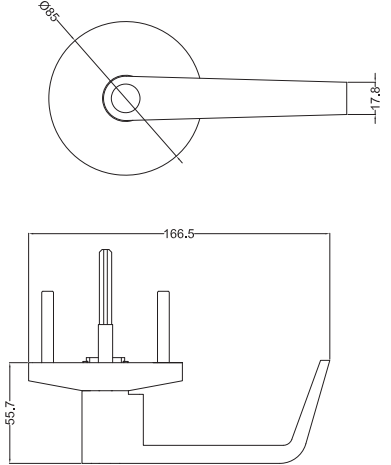
FIRE-EXIT HARDWARE 800VRD-630

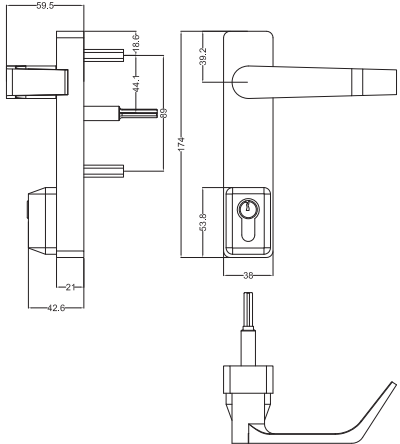

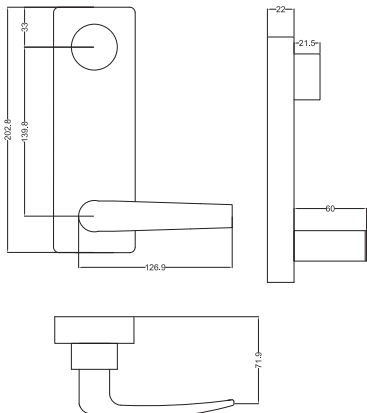
| DT004D | | DT010D | |
|-----------------------------------------------------------------------------------|-----------------------------------------------------------------------------------|------------------------------------------------------------------------------------|-------------------------------------------------------------------------------------|
|  |  |  |  |

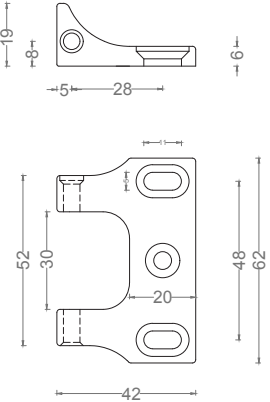
| DT009D | | SPD003-A (STRIKE FOR DOUBLE DOORS) | |
|-------------------------------------------------------------------------------------|------------------------------------------------------------------------------------|--------------------------------------------------------------------------------------|--------------------------------------------------------------------------------------|
|  |  |  |  |